



SCANDIUM

Makes life easier.



Clever
Kitchen
Appliances

Introducing a range of European quality kitchen appliances from a name you can trust.

With more than 35 years of combined experience, Axis Group International have been scouring the globe, selecting high quality kitchen appliances to bring to the Australian and New Zealand market.

We seek out the best brands in Europe, with technology and development at the forefront, and recognised Awards that are peer-driven proof of excellence in the industry.

We are also motivated by a desire to deliver quality manufacturing, with intelligent and innovative design details, that customers will enjoy for a lifetime.

Best of all, we stand by our products with a 3 Year Warranty, supported by our reliable and trusted Service Team.



To explore the range visit
www.scandiumappliances.com.au

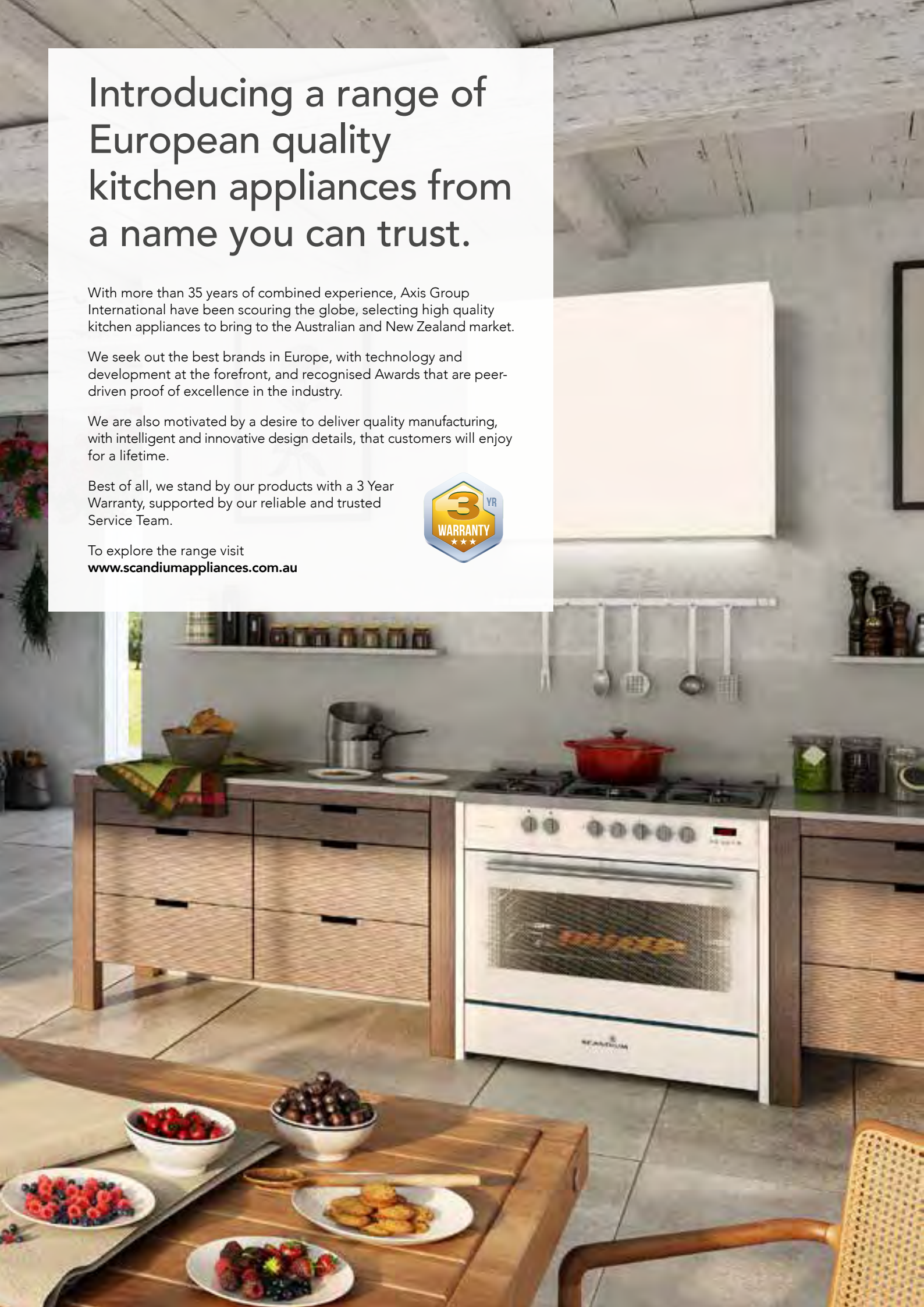



DUAL ELEMENTS + DUAL FANS FOR MORE EVEN COOKING

121L UPRIGHT GAS/ELECTRIC
FREE-STANDING OVEN // 90CM

- 8 Multi-Function Oven
- 5 Burner Gas Cooktop
- Heavy Duty Cast Iron Supports
- Centre Wok Burner
- Programmable Electronic Timer
- Triple Glazed Oven Door
- XL Cavity - 121L Gross
- Easy Clean Enamel
- Dual Fans
- Lower Warming/Storage Compartment
- Electronic Ignition
- Flame Failure Safety Device
- Max 20 amp

121L



An upright cooker in exciting colours.



SCU900S Stainless Steel



SCU900B Black



SCU900W White



SCU900PB Pale Blue



SCU900DB Dark Blue



SCU900LG Light Green



SCU900R Red



SCU900BG Burgundy



SCU900CR Cream

OVEN FUNCTIONS:



Fan Forced



Fan Assisted



Fan & Grill



Grill



Fan Assist +
Bottom
Element



Conventional
Oven



Defrosting



Light



The perfect **SILENT** rangehood for your Scandium cooktop.

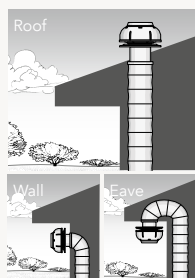

The motor silently and efficiently extracts steam, smoke, and odours and expels it externally.
 Motor mounts externally in roof, wall or eaves.

SILENT UNDERMOUNT RANGEHOOD // 60CM, 90CM

- Stainless Steel
- Silent, External Motor
- Single Speed with Switch Button Controls
- Incandescent Lights
- Aluminium, Dishwasher Safe Filters
- Motor & Ducting included - 2 boxes
- Motor Power - 600m³/hr Airflow (both models)
- Ducting - 150mm flexi-ducting (4m)
- Installs in Roof, Wall or Eave

Image is for illustration purposes only. Motor shown is not an exact product representation.





SC900WTS

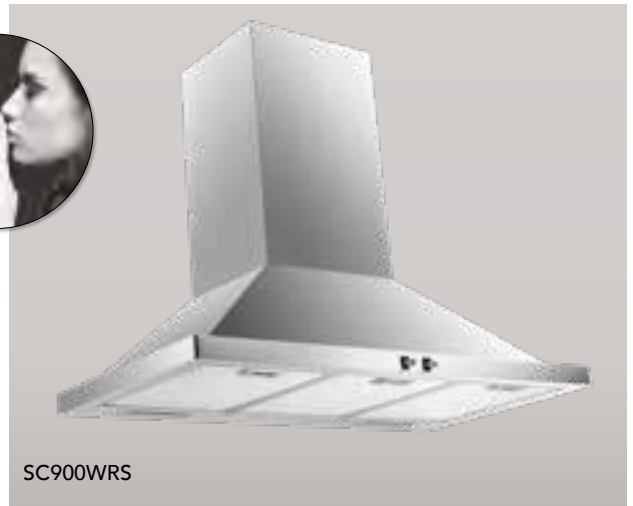

SC900WRS

**SILENT WALLMOUNT RANGEHOOD // 90CM
SC900WTS**

- Stainless steel finish
- Silent external motor system
- Single speed with switch button controls
- Incandescent lighting
- Aluminium, dishwasher safe filters
- Motor & Ducting included - 2 boxes
- Motor Power - 600m³/hr Airflow
- Installs in Roof, Wall or Eave



**SILENT WALLMOUNT RANGEHOOD // 90CM
SC900WRS**

- Stainless steel finish
- Silent external motor system
- Single speed with switch button controls
- Incandescent lighting
- Aluminium, dishwasher safe filters
- Motor & Ducting included - 2 boxes
- Motor Power - 600m³/hr Airflow
- Installs in Roof, Wall or Eave



SCUM-6C



SCUM-9C

**UNDERMOUNT RANGEHOOD // 60CM, 90CM
SCUM-6C, SCUM-9C**

- Stainless Steel Fascia
- 3 Speed with Push Button Controls
- GU 10 Warm Halogen Lights
- Aluminium, Dishwasher Safe Filters

- Internal Motor [SCUM-6C] - 760m³/hr
- Internal Motor [SCUM-9C] - 900m³/hr



SCRH60

SLIDE OUT RANGEHOOD // 60CM SCRH60

- Telescopic Slide-out Rangehood - Automatic Start
- Stainless Steel Front Fascia
- 2 Aluminium Grease Filters
- 3 Speed with Switch Controls
- Halogen Lights
- Single Internal Motor - 250m³/hr



SPECIFICATIONS

SCU900 **UPRIGHT COOKER** // 90cm

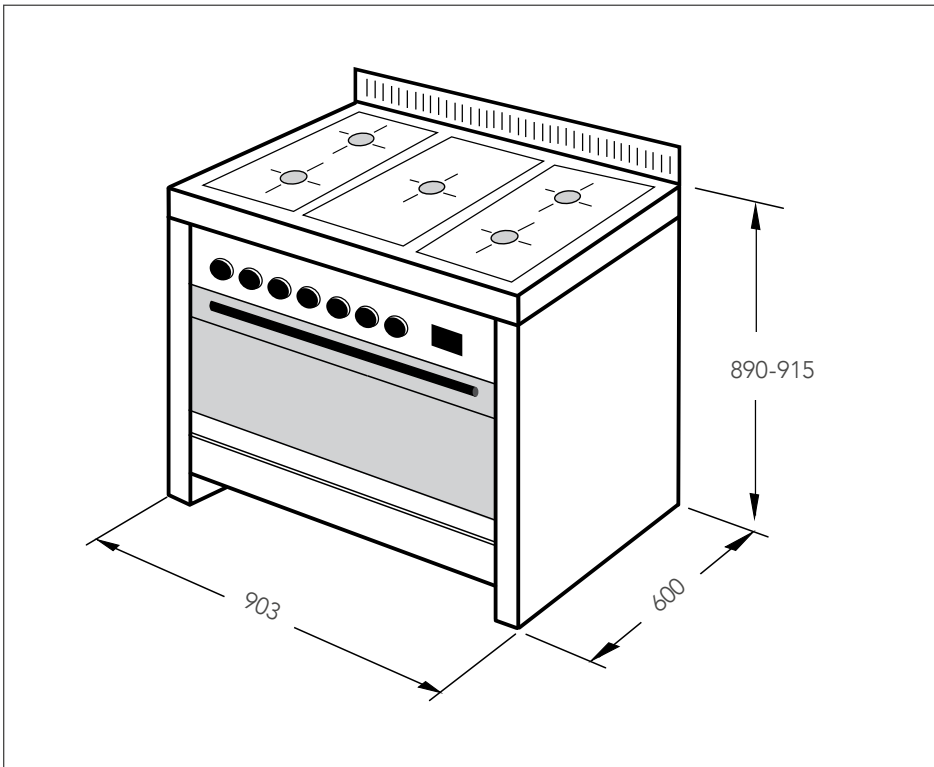

INSTALLATION

Oven requires a dedicated 20 amp circuit from socket to main switchboard. Refer your qualified technician to our product manual. Natural Gas and LPG jets supplied.

CLEANING AND MAINTENANCE

Easy clean enamel interior. Clean stainless steel using only recommended stainless steel cleaning products. No abrasives, corrosive detergents, bleaches or acids.

SC600UMS **UNDERMOUNT RANGEHOOD** / SILENT // 60cm

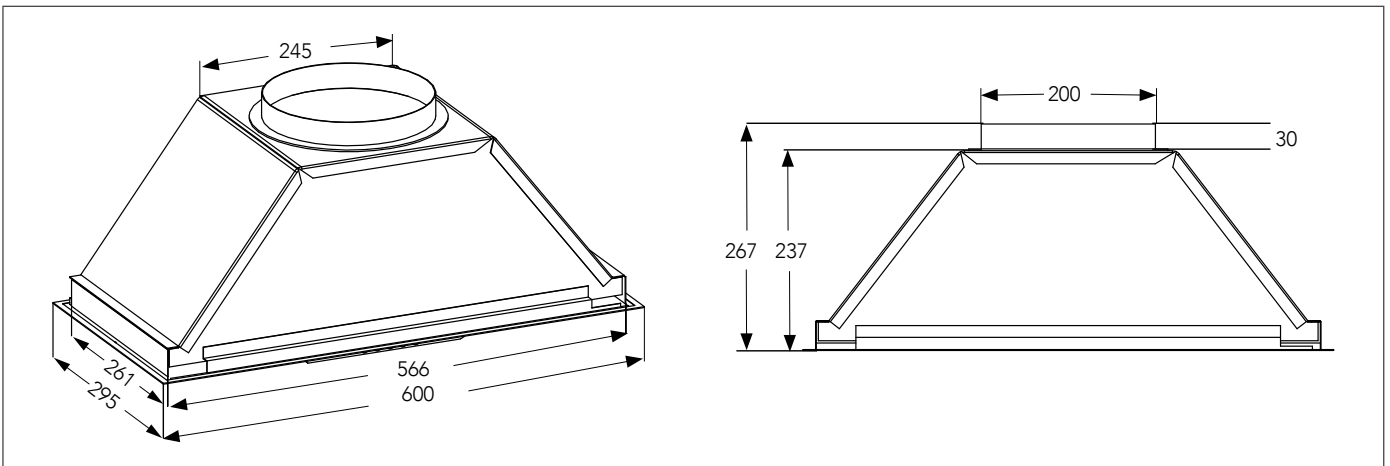

SC900UMS **UNDERMOUNT RANGEHOOD** / SILENT // 90cm

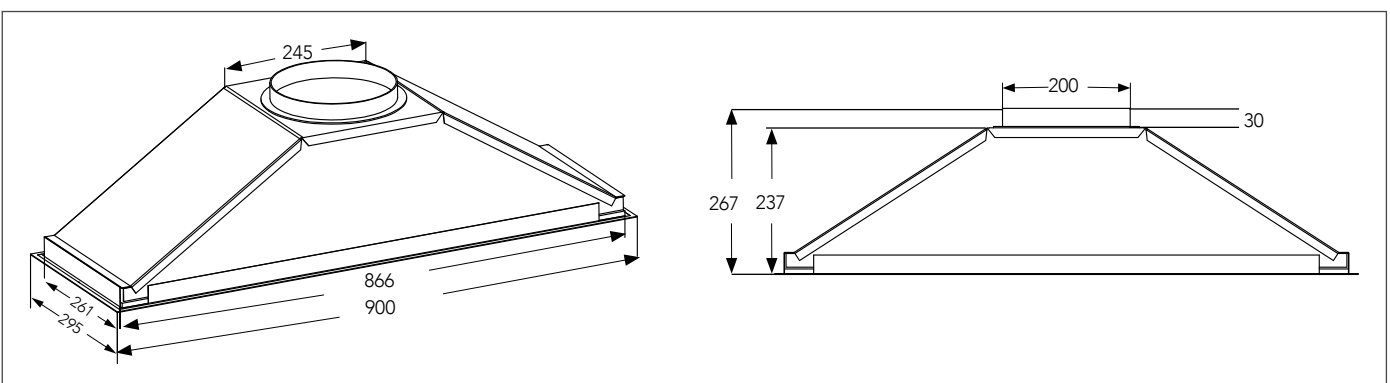

SCUM-6C UNDERMOUNT RANGEHOOD // 60cm

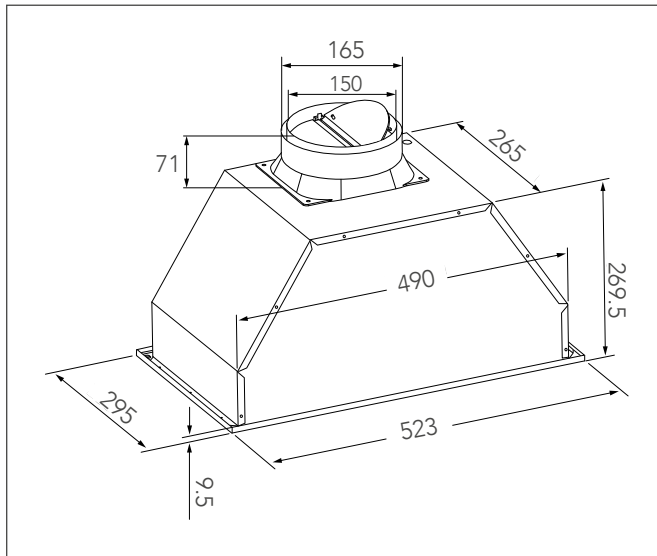

SCUM-9C UNDERMOUNT RANGEHOOD // 90cm

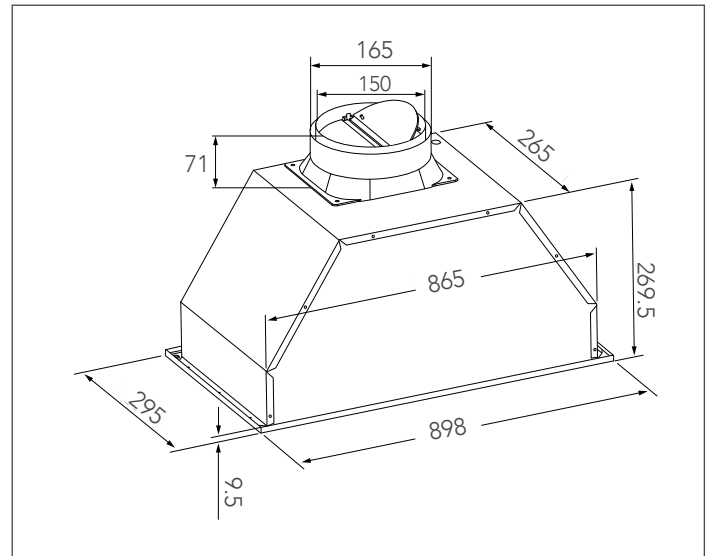

SC900WTS, SC900WRS WALLMOUNT RANGEHOOD / SILENT // 90CM

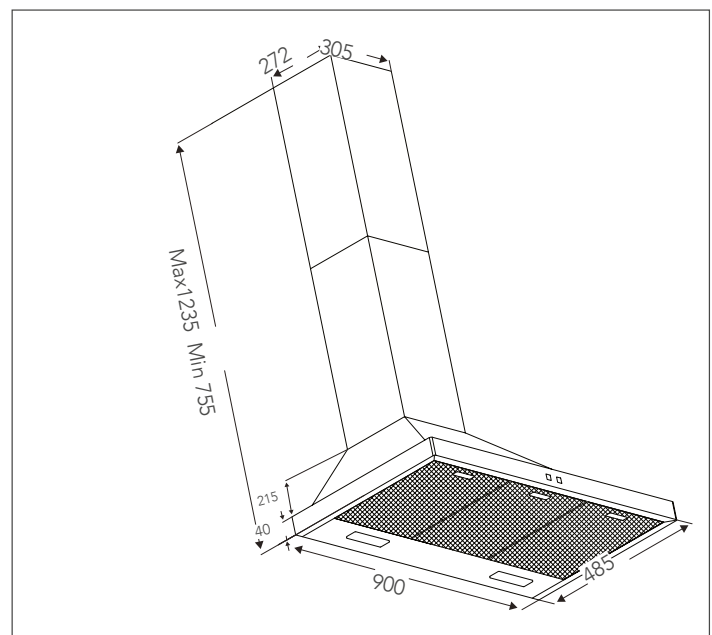
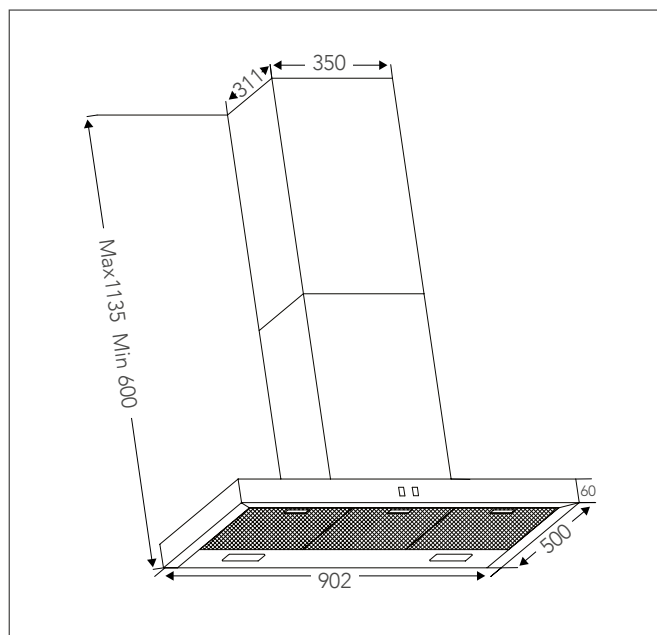

FOR ALL RANGEHOOD INSTALLATIONS

A qualified, professional technician is recommended. 10 amp plug supplied

CLEANING AND MAINTENANCE

Easy clean stainless steel using only recommended stainless steel cleaning products. No abrasives, corrosive detergents, bleaches or acids.

INSTALLATION NOTES

All measurements in millimetres.

All specifications and product sizes may be varied by the manufacturer without notice. Axis Group International are not responsible for any errors or omissions.

Pictures, specifications and dimensions are for illustration purposes only and cut-outs for appliances should only be physical product measurements. All dimensions and information are for indicative use only. Please refer to all technical specifications in the Installation Manual supplied with the appliance, prior to installation.

SCRH60 SLIDE-OUT RANGEHOOD // 60cm

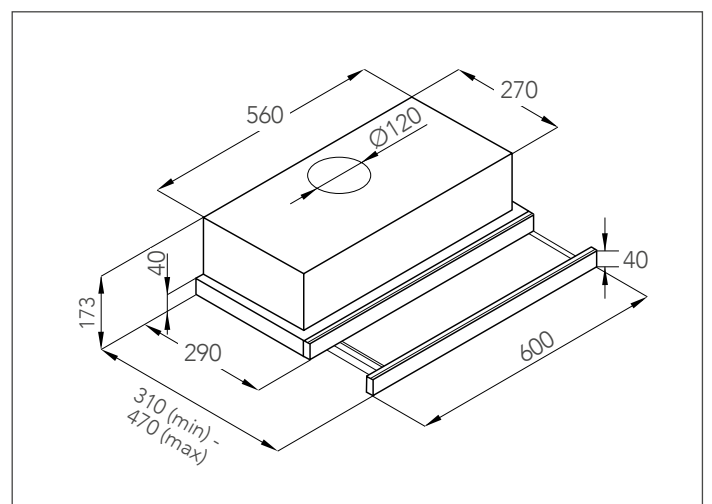

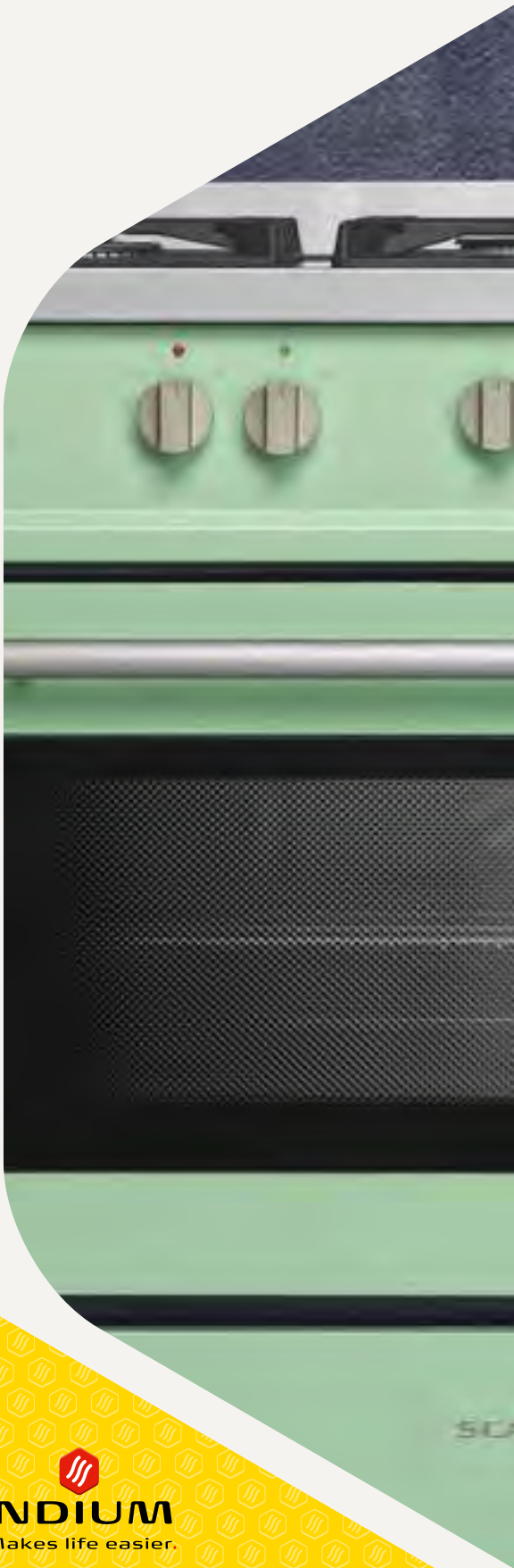

Scandium® European
Quality Kitchen
Appliances are covered
by a 3 Year Warranty,
and are serviced by our
experienced Australian
Customer Service Team.



AUSTRALIA 8/3-4 Anzed Court, Mulgrave VIC 3170. Phone 1300 881 693
Email info@scandiumappliances.com.au Web www.scandiumappliances.com.au

NEW ZEALAND 5 Tolich Place, Henderson, Auckland 0610. Phone 0800 200 510
Email info.parex@emerson.com Web www.parex.co.nz